

LTE

The future is here



Peter Busschbach

Senior Director, LTE Solution Architecture and Systems Engineering

Alcatel-Lucent

October 13, 2010

Intro

NGN:

- The Next Generation in Networking?
- Networks for the Next Generation?



LTE

LTE = Long Term Evolution

LTE = 4th Generation Wireless Technology

- (3.9G according to the experts)
- Standardized by 3GPP and included in ITU-R M1457

First commercial deployments in 2010

- TeliaSonera, MetroPCS, Verizon

Evolved Packet System Architecture Overview

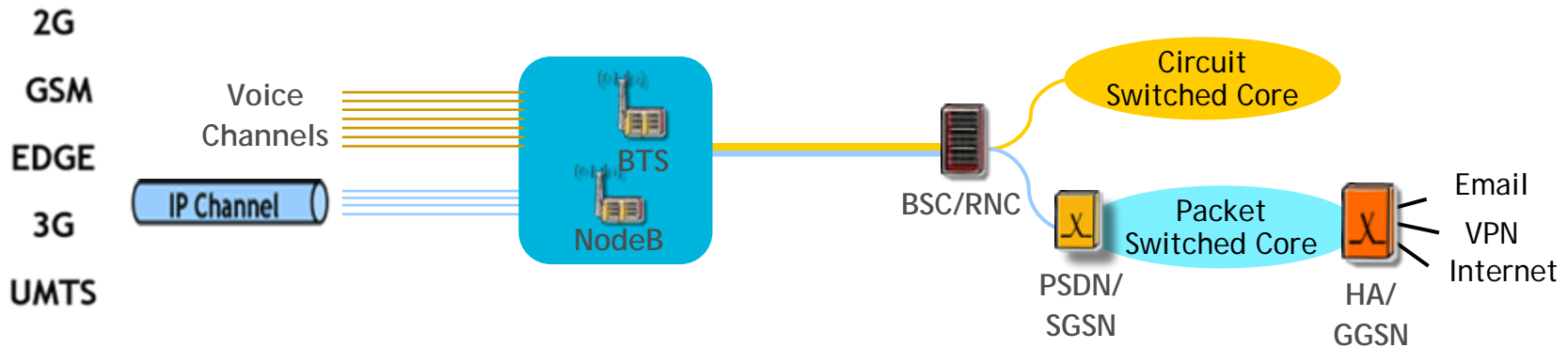

EPS is based upon an end-to-end all-IP architecture

- ❖ All services are delivered over IP
- ❖ Clearly delineated control plane & data plane
- ❖ Simplified network architecture: from 2 to 1 core
- ❖ Interworking with legacy 2G/3G and with WLAN

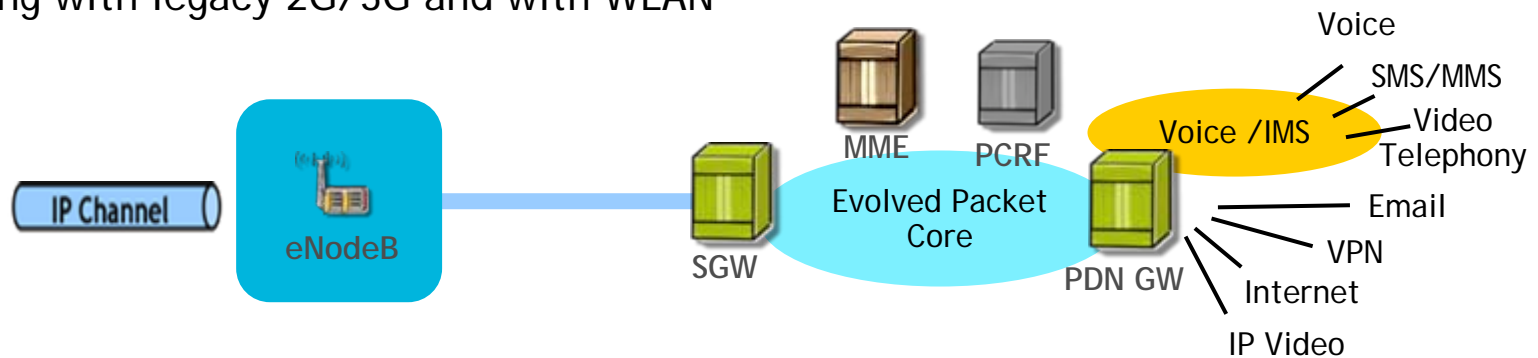

Evolved Packet Core

Mobility Management Entity

- Authenticates UE's & control access to network connections
- Selects SGW and PGW
- Performs paging

Policy and Charging Rules Function

- Policy Decision Point
- Based on Subscriber Profiles and Operator Policies determines QoS parameters and charging rules for new bearers

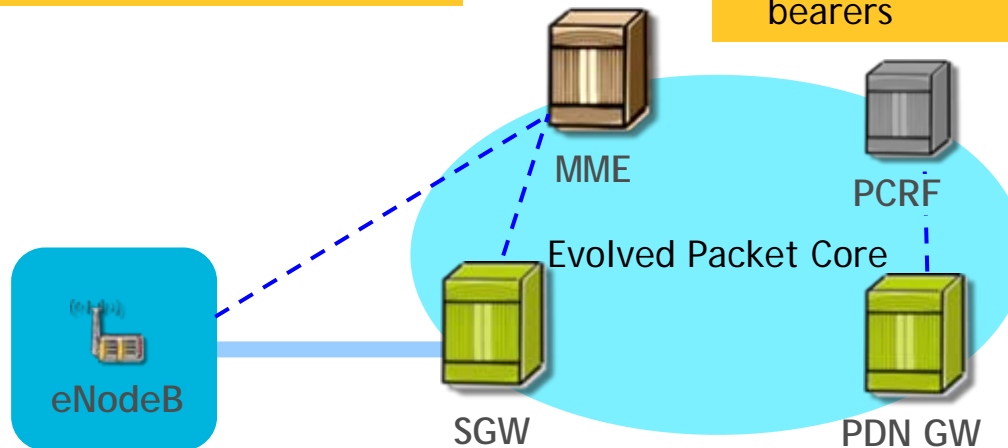

Serving Gateway

- Local mobility anchor
 - Down link packet buffer for idle-mode UEs
- Could be combined with PGW

Packet Data Network Gateway

- Anchors IP bearers
- Provides UE IP address management
- Provides Policy & Charging Enforcement Function (PCEF)
- Per-SDF based packet filtering

Wireline - Wireless Convergence

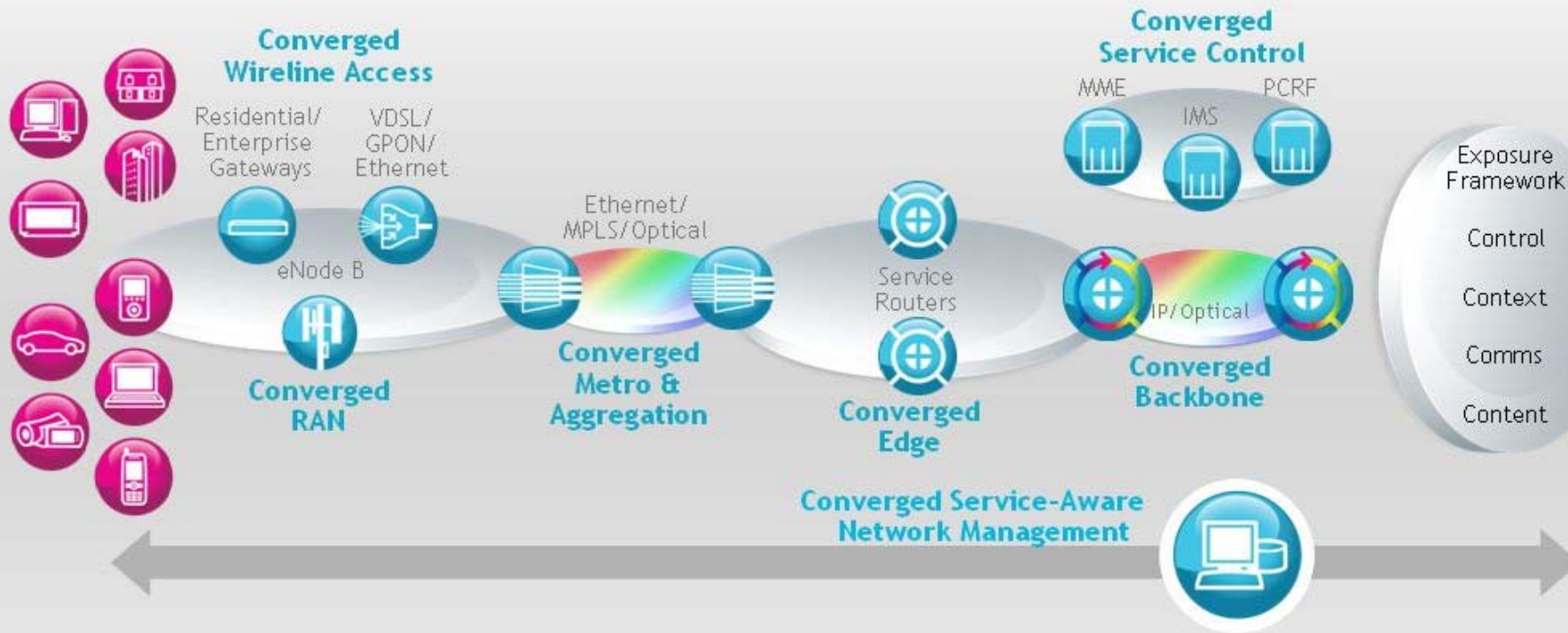

- Exposure of device and network data and features to enable new business models
- Integration with a suite of innovative application enablers
- Centralized, Dynamic Policy management (PCRF) & Distributed Policy Enforcement
- End-to-end service-aware management and optimization

Voice Services

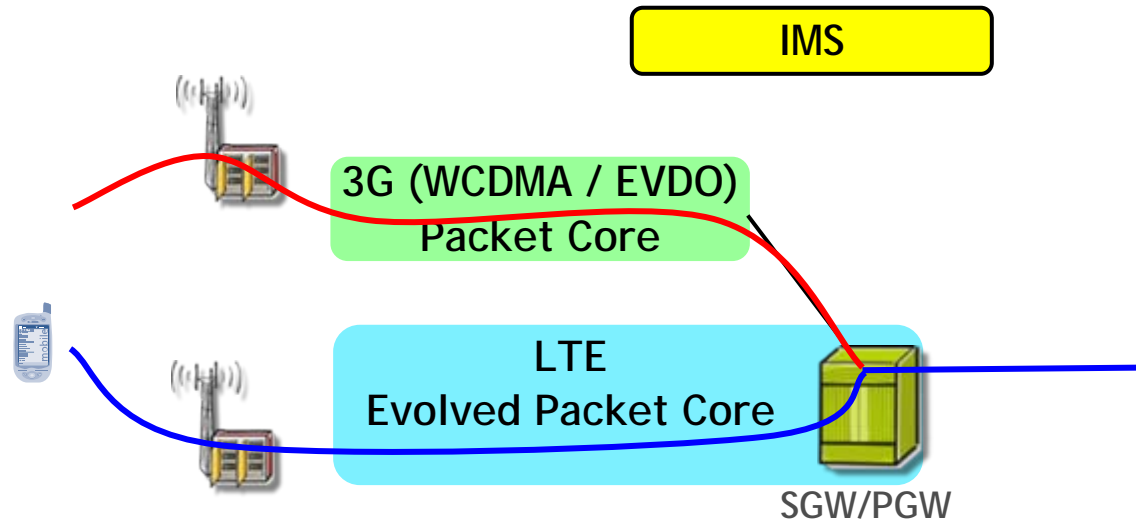

Ideally:

- Setup VoIP calls under control of IMS
- When a UE loses LTE connectivity and falls back to 3G or 2G, perform a Packet Switched Handover

But: not all 3G (or 2G) networks support the QoS required for VoIP

Voice Services - cont-d

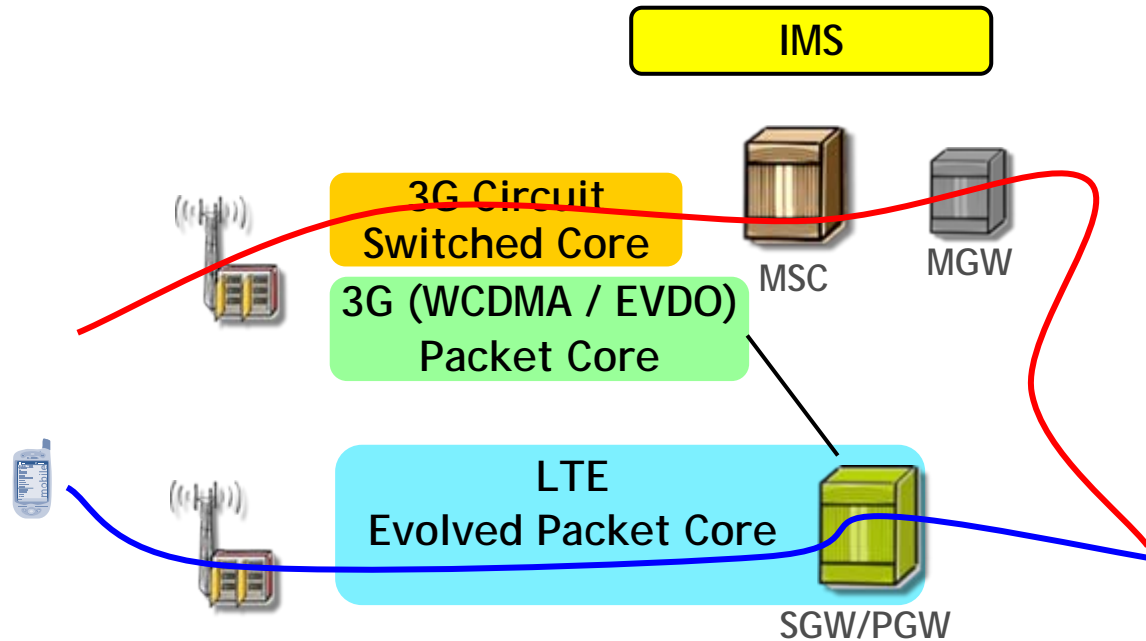

If VoIP over 3G or 2G is not supported, one needs

- Single Radio Voice Continuity (SR-VCC)
- IMS Centralized Services (ICS)

which are fairly complex and cause service providers to proceed cautiously

Voice Services - cont-d

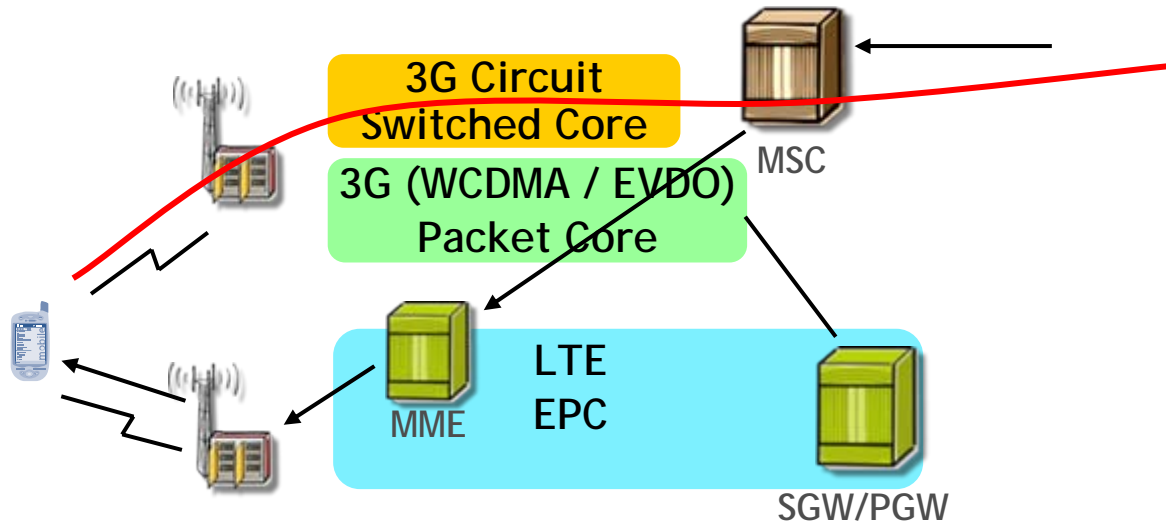

Near term solution: Circuit Switched Fallback (CSFB)

- At the beginning of a call, UE is redirected to 3G (or 2G)

Disadvantage:

- Even within LTE coverage, UE is connected to 3G for both voice and data services
- Pushes LTE devices onto heavily loaded 3G networks

Epilogue

The service provider's dilemma

- Service Providers must provide service continuity when introducing new services

... but individual users choose new services instead. E.g

- Skype
- Facebook



LTE enables Skype, Facebook and thousands of other apps

LTE:

- The next generation in networking
- The network for the next generation

